

Explosion-protected pressure switches

To ATEX standard



- ATEX-certification for use in potentially explosive areas
- Switching point can be easily adjusted by the user whilst system in operation
- Compact design
- Excellent price/performance ratio

Explosion-protected pressure switches

Technical details

M.8
ATEX



Technical explanations

Explosion-protected pressure switches are classified according to the respective combustible material-type. This division is:

Gases and vapours 0165	Dusts 0340 / 0341	Methane dust not suitable
----------------------------------	-----------------------------	-------------------------------------

Our pressure switches are generally designed for use with gases, vapours or dust.

Our explosion-protected pressure switches are not approved for use with methane dust (mining applications).

The table provides an overview of the zone divisions, equipment groups and equipment categories.

Conditions in potentially explosive atmosphere

Com-bustible materials	Temporary behaviour of combustible materials in potentially explosive area	Categorisation of potentially explosive areas	Marking required on equipment to be used	
			Equipment group	Equipment category
Gases Vapours	are present continually, frequently or for long periods	Zone 0	II	1G
	occur occasionally	Zone 1	II	2G or 1G
	are unlikely to occur, and if so, are then only seldom or for short periods	Zone 2	II	3G or 2G or 1G
Dusts	are present continually, frequently or for long periods	Zone 20	II	1D
	occur occasionally	Zone 21	II	2D or 1D
	occur if accumulated dust is whirled up, and then only seldom or for short periods	Zone 22	II	3D or 2D or 1D
Methane dust	–	Mining industry	I	M1
	–	Mining industry	I	M1 or M2



Explosion-protected pressure switches

Technical details

Type:	0165	0340 / 0341	
ATEX protection zone:	1 and 2	22	
Combustible Material:	Gases and vapours	Dusts	
Rated working voltage:	10 ... 250 VAC	10 ... 250 VDC	10 ... 250 VAC
Rated working current:	10 mA ... 1 A	10 mA ... 250 mA	10 mA ... 2 A
Temperature resistance:	NBR	-20 °C ... +80 °C	
	EPDM	-20 °C ... +80 °C	
	FKM (in diaphragm pressure switch)	-5 °C ... +80 °C	
	FKM (in piston pressure switch)	-15 °C ... +80 °C	
Switching frequency:	200 / min		
Mechanical life expectancy:	1,000,000 cycles		
Pressure rise rate:	≤ 1 bar/ms		
Hysteresis:	0 ... 30 % (depending on type, non-adjustable)		
Vibration resistance:	10 g; 5 ... 200 Hz sine wave; DIN EN 60068-2-6		
Shock resistance:	294 m/s ² ; 14 ms half sine wave; DIN EN 60068-2-27		
Cable length:	Standard length approx. 2m with wire end sleeve, also available in lengths of approx. 5m.		
Cable cross-section:	3 x 0,75 mm ²		3 x 0,5 mm ²
Housing material:	Aluminium		Zinc-plated steel (CrVI-free) anodised aluminium
Protection class:	IP65		
Weight:	approx. 380 g		approx. 230 g

0165

Diaphragm / piston pressure switches up to 250 V

ATEX 0102 C€  II 2G Ex d II C T6 / T5 X (gas-protected zones 1 and 2)

- Aluminium housing
- Changeover with silver contacts
- Operating voltage up to 250 V
- Overpressure safety up to 200 / 600 bar¹⁾

p_{max} in bar	Adjustment range in bar	Tolerance at room temperature in bar	Thread	Order number
---------------------	----------------------------	---	--------	--------------

0165 Diaphragm pressure switches

p_{max} ¹⁾	1 – 6	± 0.5	G 1/4 female	0165 - 448 14 - X - 001
	5 – 50	± 3.0		0165 - 449 14 - X - 001

0165 Piston pressure switches

p_{max} ¹⁾	20 – 100	± 3.0 – 5.0	G 1/4 female	0165 - 450 14 - X - 001
	25 – 250	± 5.0 – 7.0		0165 - 452 14 - X - 001
	100 – 400	± 5.0 – 9.0		0165 - 451 14 - X - 001

Seal material – Application areas

NBR	Hydraulic/machine oil, heating oil, air, nitrogen, etc.	1
EPDM	Brake fluid, water, hydrogen, oxygen, acetylene, etc.	2
FKM	Hydraulic fluids (HFA, HFB, HFD), petrol/gasoline, etc.	3

Refer to page 82 for the temperature range and application thresholds of sealing materials.

Your order number: **0165 - XXX 14 - X - 001**

Piston pressure switches only have limited suitability for use with gases (refer to Page 14 for explanations).

M.8
ATEX

Suco



Contact assignment:

- 1 = white
- 2 = green
- 4 = brown

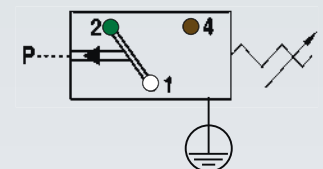

¹⁾ Static value. Dynamic value is 30-50 % lower. Values pertain to the hydraulic/pneumatic part of the pressure switch.

M

0340 / 0341

Diaphragm / piston pressure switches up to 250 V

ATEX CE II 3D IP65 T90°C (dust protection zone 22)

- Zinc-plated steel housing (CrVI-free), with anodised aluminium protective cap
- Changeover with silver contacts
- Operation voltage up to 250 V, protection class 2, protective insulation \square
- Overpressure safety up to 300 / 600 bar¹⁾



Contact assignment

- 1 = black
- 2 = red
- 4 = white

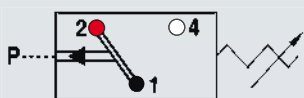

P_{\max} in bar	Adjustment range in bar	Tolerance at room temperature in bar	Thread	Order number
----------------------	----------------------------	---	--------	--------------

0340 Diaphragm pressure switches

300 ¹⁾	0.3 – 1.5	± 0.2	G 1/4	0340 - 457 03 - X - 003
	1 – 10	$\pm 0.5 - 1.0$		0340 - 458 03 - X - 006
	10 – 20	± 1.0		0340 - 459 03 - X - 009
	20 – 50	± 2.0		0340 - 461 03 - X - 012

0341 Piston pressure switches

600 ¹⁾	50 – 150	± 5.0	G 1/4	0341 - 460 03 - X - 003
-------------------	----------	-----------	-------	-------------------------

Seal material – Application areas

NBR	Hydraulic/machine oil, heating oil, air, nitrogen, etc.	1
EPDM	Brake fluid, water, hydrogen, oxygen, acetylene, etc.	2
FKM	Hydraulic fluids (HFA, HFB, HFD), petrol/gasoline, etc.	3

Refer to page 82 for the temperature range and application thresholds of sealing materials.



Your order number: **034X - XXX 03 - X - XXX**

Piston pressure switches only have limited suitability for use with gases (refer to Page 14 for explanations).

¹⁾ Static value. Dynamic value is 30-50 % lower. Values pertain to the hydraulic/pneumatic part of the pressure switch.

Technical explanations for mechanical pressure switches

Diaphragm pressure switch
NO

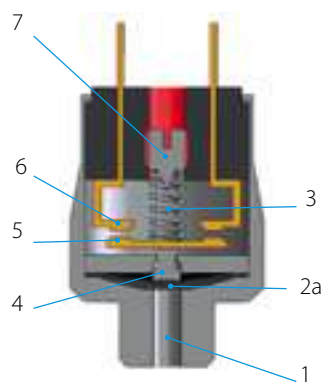

Piston pressure switch
NC

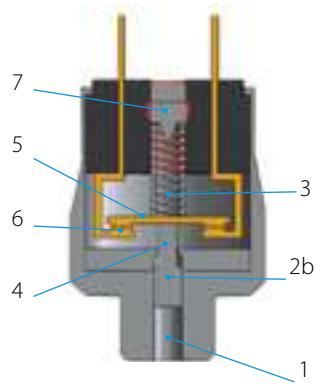

Change-over

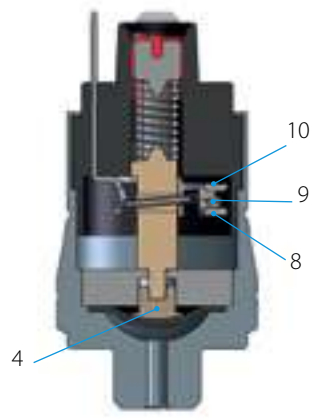

What is a mechanical pressure switch?

Mechanical pressure switches from SUCO monitor the pressure of liquid or gaseous media, and close or open an electrical circuit on reaching a set threshold.

Diaphragm pressure switches

SUCO diaphragm pressure switches are used in pressure ranges from 0.1 bar to 100 bar, meaning overpressure safety of 35, 100, 300 and 600 bar, depending on the used diaphragm type.

Piston pressure switches

Pressure ranges from 10 bar to 400 bar can be monitored with SUCO piston pressure switches (dependent on size); overpressure safety of up to 600 bar can be attained.

Sizes of pressure switches

Mechanical pressure switches from SUCO can be divided into sizes hex 24, hex 27 and 30 A/F. Each particular size has specific hydraulic, pneumatic and electric properties (specified on the relevant catalogue page in the technical details).

How does a pressure switch work?

Function description for **normally open (NO)**: Pressure is applied to the diaphragm (2a) / pistons (2b) through the pressure connector (1).

If the generated pressure force is greater than the force of the pre-tensioned pressure spring (3), the plunger (4) moves towards the counter-contact (6), carrying along the contact disc (5), and closes the circuit.

The switch opens again when the pressure is reduced by the hysteresis value.

Function description for **normally closed (NC)**: Engaging happens in the reverse order.

The adjustment screw (7) enables the switching point to be changed within the adjustment range.

The micro switch of a **change-over contact system** (snap-action) offers both, a NC and a NO contact.

The swivel contact (9) is activated by the plunger (4). The circuit is closed by the NC (8) as long as no pressure is applied. When the applied pressure exceeds the set switching point, the swivel contact changes over and closes the circuit via the NO (10).

Utilisation category

The utilisation category specifies for example voltages and currents, and the type of load, our pressure switches are designed for (according to DIN EN 60947-5-1).

AC voltage

AC12: Control of ohmic loads and semiconductor loads in input circuits of optocouplers (such as PLC inputs).

AC14: Control of electromagnetic loads, 72 VA.

DC voltage

DC12: Control of ohmic loads and semiconductor loads in input circuits of optocouplers (such as PLC inputs).

DC13: Control of electromagnets.

B10d value

According to DIN EN ISO 13849-1, the B10d value specifies the anticipated service life (with a 10% probability of failure). The B10d value is therefore directly dependent on the respective application of the pressure switch. For ohmic loads and currents < 1 A, we specify the B10d value as 1 million cycles of electrical life.

The specification of a MTTF time (mean time to failure) is not possible without knowing the specific conditions in the application. However, the MTTF time can be determined easily from the B10d value:

$$MTTF_d = \frac{B_{10d}}{0,1 n_{op}}$$

n_{op} : number of cycles per year

B_{10d} : number of cycles until 10 % of components have failed.

Classification of electrical switch functions

			Contact form DIN EN- 60947-5-1	Symbol IEC 60617
NO	NO, normally open	SPST single pole, single throw	X	
NC	NC, normally closed	SPST single pole, single throw	Y	
Change-over contacts	CO, change over (snap action)	SPDT single pole, double throw	C	

Minimum current / minimum working voltage

The minimum working current and minimum working voltage depend greatly on operating and ambient conditions. Physically, the build-up of impurity layers on the contact rivets must be countered with mechanical friction and/or electrical erosion.

It has proven useful in many applications to deploy our pressure switches with silver contact rivets ensuring that they are fail safe to 10 mA and 10 V. Variants with gold contacts are available in our catalogue for even lower currents and voltages.

Potential-free – galvanically isolated

Mechanical pressure switches from SUCO are potential-free, i.e. no auxiliary energy is required. Also, there is no electrical contact between the individual, live parts and the housing.

Adjustment range of switching point

The pressure range, within which the switching point of a pressure switch can be set, is called adjustment range. The switching point corresponds to the pressure value at which the electric circuit is opened or closed by the pressure applied.

If no switching point is specified on order, the pressure switches are adjusted by approximately half the adjustment range at factory.

Switching point tolerances

The switching point tolerances specified by us pertain to room temperature (RT) and condition as new. The values can change as a result of temperature, ageing and deployment conditions.

It is not possible to specify generally applicable value for switching point tolerances over temperature as the medium has a significant influence on the sealing materials in the pressure switch.

Double the tolerance stated for RT and condition as new can be assumed as a typical magnitude for the tolerance over the entire temperature range.

Based on their design, piston switches may exhibit an increase in switching points due to storage (dry run, stick-slip effect). Following a short start phase, the switching points return to the value set at the factory.

Pressure change rates of > 1 bar/s may have an effect on the switching point for diaphragm pressure switches.

The switching point (for rising pressure) and hysteresis increase, whilst the switch-back point (for falling pressure) sinks. Also, the effect of the maximum (system) pressure on the switchback point (for falling pressure ramp) must be factored in for tolerance-critical applications. The higher the (system) pressure, the lower the resulting switch-back value.

Hysteresis

Rising / falling switching point

The pressure difference between the rising (upper) and falling (lower) switching points (refer to the figure, e.g. NO) is known as hysteresis (switch-back difference).

Hysteresis has no constant value due to the structural layout of a mechanical pressure switch. In absolute values, the hysteresis is also the smallest with the smallest adjustment range. The hysteresis increases with increasing adjustment range.

Hysteresis over rising switching point

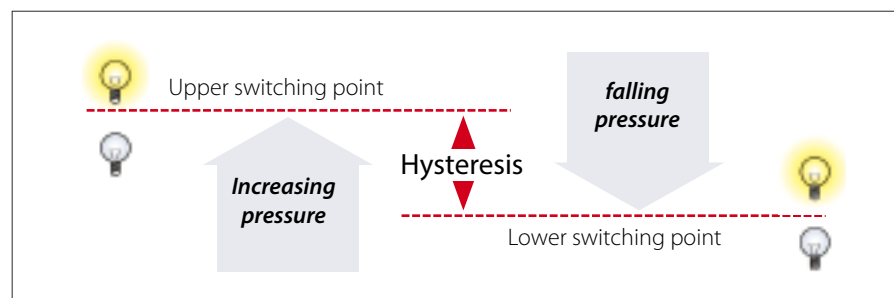
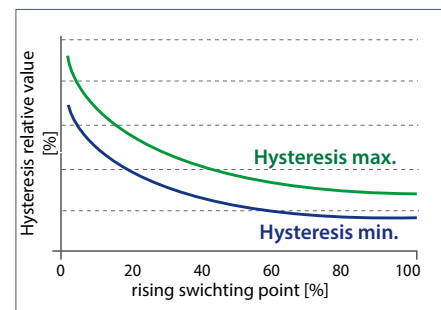
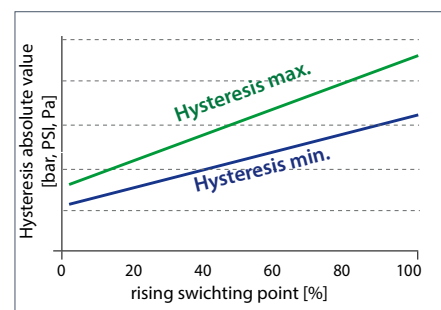

Technical explanations for mechanical pressure switches

Hysteresis can be set at SUCO in range from approx. 10 % (at end of adjustment range) to 30 % or higher (at start of adjustment range), related to the respective switching point for hex 27 and 30 A/F pressure switches with adjustable hysteresis.

The specifications in the catalogue only represent typical average values.

Please ask about the possible setting ranges you may require. Our electronic pressure switches are excellently suited to extremely low or high hysteresis.

The lowest possible hysteresis is set if nothing is specified in the order.

Switching frequency

The switching frequency provides information on the possible number of cycles in one minute. The value of 200/minute specified by us is a guideline value. Higher switching frequencies can be attained depending on switch type and conditions of use.

Sealing materials

The priority in sealing material selection is the chemical resistance. The temperature range only becomes a selection criterion when different sealing materials are suitable for the medium.

NBR (Buna-N)

This is the standard material most commonly used. It is a special SUCO material mix with high level of cold flexibility so that the sealing properties of the pressure switch are also retained at low temperatures.

NBR is denoted by number „1“ in our order number.

EPDM

This material is the solution of choice for applications with brake fluids. It is particularly suitable for applications with (process) water. Approval from the BAM (Federal Institute for Material Testing) is in place for oxygen applications. The safety regulations from country-specific authorities must be observed for oxygen applications.

EPDM may not come into contact with oil because this would entail swelling and softening of the material, and so failure of the pressure switch.

EPDM is denoted by number „2“ in our order number.

EPDM-TW with drinking water approval

This EPDM material is intended for drinking water applications according to Elastomer Guideline, WRAS (Water Regulation Advisory Scheme), ACS (Attestation de Conformité Sanitaire) and NSF 61 (National Sanitation Foundation) and for use in medical and pharmaceutical applications.

EPDM-TW may not come into contact with oil because this would entail swelling and softening of the material, and so failure of the pressure switch. Sealing is only available upon request, so please consult us before ordering.

EPDM-TW is denoted by number „5“ in our order number.

FKM / FPM (Viton®)

This is a diaphragm material suitable for high temperature exposure and exhibits special chemical resistance. It has been tested in the hydraulic sector and has been proven to work successfully with critical oils.

FKM / FPM is denoted by number „3“ in our order number.

FFKM

This diaphragm material is suitable for temperature exposure up to 120°C and can withstand very aggressive conditions such as chemical species including organic or inorganic acids, diluted alkalis, ketones, esters, alcohols, fuels and hot water.

FFKM is denoted by number „6“ in our order number.

TPE (Thermoplastic elastomers)

This sealing material is available only for our electrical products of the Performance Series.

TPE offers similar media compatibility like NBR, e.g. suitable for mineral oil and hydraulic fluids.

Additionally the material can be used with diluted acids and bases and cold water, too.

TPE is denoted by number „7“ in our order number.

ECO (epichlorhydrin)

ECO is only used in our vacuum switches. This material has similar properties to NBR in terms of chemical resistance, and can be used in gas applications as well as oil and fuel applications.

ECO is denoted by number „4“ in our order number.

Silicone

Silicone is suitable for use within a wide temperature range. The SUCO silicone diaphragm is FDA-approved (Food & Drug Administration) for the food sector.

Silicone is a soft material reserved for sensitive applications in the low pressure range (below 10 bar) with maximum overpressure safety to 35 bar. Piston switches are therefore not offered with silicone seals. Silicone is also not suitable for oil applications.

Silicone is denoted by number „8“ in our order number.

H-NBR

This is a special SUCO material mixture optimised for ester-based bio-oils. The multitude of bio-oils on the market means suitability of the material for the respective oil must be determined. This diaphragm material can also be used for a number of mineral and synthetic oils.

H-NBR is denoted by number „9“ in our order number.

Medium compatibility

The specifications on medium compatibility in this catalogue cannot be generalised as they pertain to the sealing materials used in our pressure switches.

Saturated and superheated steam applications

The sealing materials mentioned are not suitable for saturated or superheated steam applications.

Conversion table for pressure units

Unit symbol	Unit name	Pa= N/m ²	bar	Torr	lbf/in ² , PSI
1 Pa = N/m ²	Pascal	1	0.00001	0.0075	0.00014
1 bar	Bar	100 000	1	750.062	14.5
1 Torr = 1 mmHg	Millimetres, mercury column	133.322	0.00133	1	0.01934
1 lbf/in ² = 1 PSI	Pound-force per square inch	6 894	0.06894	51.71	1

Conversion table for temperature units

	K	°C	F
K	1	K - 273.15	9/5 K - 459.67
°C	°C + 273.15	1	9/5 °C + 32
F	5/9 (F + 459.67)	5/9 (F - 32)	1

Water applications

Standard piston switches are not suitable for water applications.

Pressure switches in stainless steel with EPDM seal have a special sealing system and can therefore also be used for water with corrosion protection, water mixtures or emulsions. The use of other fluid mixtures should be clarified with SUCO (e.g. swelling of EPDM sealing could happen by water – oil mixture).

Pressure switches with stainless steel housings with EPDM-TW diaphragm, SUCO type „5“ are designed for the use of drinking water.

Gas applications

Our pressure switches are suitable for liquid and gaseous media. Gaseous media place particular demands on leak-tightness however. The leakage rate is dependent on the respective gaseous medium, the working pressure and the permeability of the seal material used in the pressure switch.

Their lower leakage rates mean diaphragm pressure switches are better suited for gas pressures than piston pressure switches. The latter can also be used however if certain measures are taken (such as venting of the housing).

For gaseous applications below 10 bar (145 PSI) in combination with pressure switches with high IP class, i.e. IP 67 and IP6K9K, in general we recommend to use ventilation. Please consult us; we are able to offer suitable solutions.

Oxygen applications

Our mechanical pressure switches are suitable for use with oxygen. We recommend the use of our EPDM diaphragm. The resistance to internal burnout of the diaphragm has been tested by the BAM (Federal Institute for Material Testing).

Pressure switches with steel housings with zinc-nickel coating are, in conjunction with oxygen, only approved to a maximum working pressure of 10 bar.

Pressure switches with brass housings are, in conjunction with oxygen, only approved to a maximum working pressure of 35 bar.

Pressure switches with stainless steel housings are, in conjunction with oxygen, only approved to a maximum working pressure of 50 bar.

DGUV accident prevention regulations (such as DGUV 500, Section 2.32 and BGI 617) must be observed for first operation.

Please specify when ordering „oil and grease-free, for use with oxygen“.

Underpressure safety of pressure switches

Our pressure switches are underpressure safe down to 300 mbar (relative).

Overpressure safety of vacuum switches

Our vacuum switches are overpressure safe up to 20 or 35 bar depending on type.

cCSAus approval

Almost all of our mechanical pressure switches (sizes hex 24 and hex 27), and vacuum switch 0151, have cCSAus approval. The CSA mark together with „c“ and „us“ combines the control stamps for introduction onto the Canadian and American markets. The cCSAus certificate also includes the test of the relevant UL standard.

Checked by an official institution and verified with regular company visits by CSA inspectors, this approval guarantees the highest levels of quality and operational reliability for our products.

You can download the current cCSAus certificate on the download area of our homepage: <http://www.suco.de/en/downloads>

Product information

The technical information in this catalogue is based upon fundamental testing during product development, as well as upon empirical values. The information cannot be used for all application scenarios.

Testing of the suitability of our products for a specific application (e.g. also the checking of material compatibilities) rests under the responsibility of the user. It may be the case that suitability can only be guaranteed with appropriate field testing.

Please consult us about gas, water and oxygen applications.

Subject to technical changes.



General technical explanations

User information

Our pressure monitoring products may only be installed and started up by authorised specialists. The safety regulations of country-specific authorities must be observed, especially when working with mains voltages and oxygen, and in potentially explosive areas.

Product information

The technical information in this catalogue is based upon fundamental testing during product development and empirical values. The information cannot be used for all application scenarios.

Testing of the suitability of our products for a specific application (such as the checking of material compatibilities) remains the responsibility of the user. It may be the case that suitability can only be verified by appropriate field testing.

Mounting position

For mechanical and electronic pressure switches as well as transmitters there is no limitation due to the mounting position with regard to the accuracy of the pressure measurement.

However, other boundary conditions of the application may require a certain mounting position, e. g. horizontal installation to avoid waterlogging on the electrical connection or vertical installation to prevent debris from accumulating in the bore of the pressure connection.

IP protection class

The IP protection class is a defined protection level code (sealing) of electrical equipment housings in line with IEC 60529 (formerly DIN 40050 – Part 2). Protection of a housing against the following is tested here:

- The penetration of solid extraneous particles, such as dust
- Access of hazardous parts
- Penetration of water

IP protection tests are performed as type tests.

The IP protection type code, made up of two digits, specifies the protection of a housing against the penetration of solid extraneous particles and water.

The numeric code therefore provides conclusions to be drawn on the level of personal safety as well as the functional protection / mid to longterm functional reliability of electrical equipment.

Protection types IP00, IP65, IP67 and IP6K9K

IP00:

No protection against penetration of solid particles or water, no protection against contact.

IP6X:

Protection against penetration of dust (dust proof). Full contact protection.

IPX5:

A jet of water from a nozzle, aimed at equipment (such as a pressure switch) from all directions, must not have any harmful effect.

IPX7:

Protection from water, when equipment (such as a pressure switch) is immersed in water under defined pressure and time conditions. Water must not penetrate into the equipment in harmful quantities.

IP6K9K:

Devices satisfying these requirements must be dust-proof and be able to withstand loads during the use of high-pressure cleaners and steam jets. The standard stipulates a water pressure from 80 to 100 bar at a temperature of 80 °C for testing.

IP6KX:

Dust must not penetrate. Letter K: Specific to the electrical equipment of road vehicles.

IPX9K:

Protection against penetration of water at high pressure / for steam jet cleaning. Water aimed at the housing from every direction at greatly increased pressure may not have any damaging effects.

We are able to offer IP67 / IP6K9K for many of our mechanical and electronic pressure switches (pre-wired or with integrated connector) and for our transmitters.

IP67 / IP6K9K is the recommended protection for mobile hydraulics and any equipment exposed to the outdoor environment.

Cylindrical threads

Cylindrical threads are either sealed on the front by underlaying an appropriate sealing ring (such as a copper sealing ring) or by already having integrated O-rings or gaskets.

If the corresponding thread types do not provide specifications regarding the roughness of the counter sealing surface, we recommend the following values:

- R_{amax} 1,6
- R_{max} 6,3
- $R_{min}(-0,10) > 5\% C_{ref}$ 5 %

Conical threads (cone-shaped threads)

Conical threads guarantee tolerance compensation of the two threaded parts. The sealing function is realised with thread flanks which deform permanently and enter into a metallic frictional fit. Conical threads are not screwed in down to the screw-in depth, but fixed with the tightening torque required for the leak tightness.

Remember not to exceed the permitted tightening torque of the pressure switch or transmitter presented in the following table (to prevent damaging the threaded pin beforehand, causing it to become untight during operation or to snap off when tightened).

Tightening torques of steel threads

The specifications below are to be understood upper material thresholds for the housing of pressure switches or transmitters. Remember during installation that the type and material of the seal, the condition of mating surfaces (e.g. dry or oily) and the material of the counter-piece all have a bearing on the tightening torque.

Thread	Tightening torque
NPT 1/8; M 10 x 1 conical	max. 18 Nm
M 10 x 1 cyl.; G 1/8	max. 20 Nm
M 12 x 1.5; 7/16 – 20 UNF	max. 30 Nm
G 1/4; 9/16 – 18 UNF	max. 40 Nm
NPT 1/4; M 14 x 1.5	max. 40 Nm

Values 30% lower than in the table above must be used for brass housings.

Gaseous applications

In particular using additional sealant to attain the required leak tightness may be necessary for gas applications.

Vacuum

The values given in the technical details for the vacuum range are specified in millibars (mbar) below atmospheric pressure.

Pressure change rate (~rise / ~fall)

The pressure change rate denotes the pressure over time for the rising/falling pressure. The pressure change rate is specified in bar/s or bar/ms.

The maximum pressure change rate for SUICO mechanical pressure switches is 1 bar/ms (1,000 bar/s).

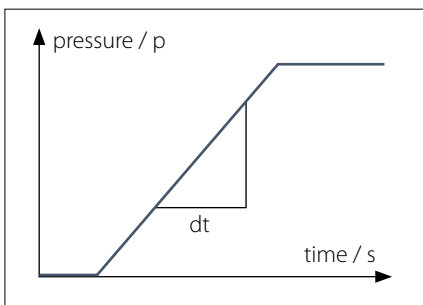

For SUICO electronic pressure monitoring products the maximum pressure change rate can be up to 5 bar/ms (5,000 bar/s).

Overpressure protection

The specified overpressure protection in the catalogue is based on a static pressure. The values refer to the hydraulic or pneumatic part of the switch. It is best practice to use 30 - 50% lower values for dynamic pressure compared to static pressure. These empirical values are based on the knowledge that, in pressure systems, unexpected pressure peaks which are higher than the working pressure are generated as a result of activation of valves, sudden falling or rising load or simply the change of cross-sections in the pipes. With conventional measurement techniques (such as manometers), these pressure peaks are hardly measurable. Faster measurement systems must therefore be used for this data acquisition. Attempts are being made to take this into account by using empirical or corrective factors.

If the pressure conditions are known and the pressure change rates are 0.1 bar/ms, our pressure switches and transmitters can be used up to the permitted overpressure protection as per data sheet / catalogue. Only 50 % of the specified overpressure protection is permitted when operating at the maximum permitted pressure change rate of ≤ 1 bar/ms for mechanical pressure switches, and at ≤ 5 bar/ms for transmitters.

RoHS-Compliance

RoHS

= Restriction of Hazardous Substances (EC Directive 2011/65/EU (RoHS II))



CE-Mark

= Communauté Européenne European Parliament and Council directives must be observed when products are launched onto the market. If a directive exists for a product, it must be applied. Only products for which a directive exists may bear the CE mark.

Only products which have been tested according to CE directive or corresponding standards may carry the CE mark.

Mechanical pressure switches with a supply voltage above 50 VAC or 75 VDC are covered by the 2014/35/EU Low Voltage Directive. Variants for potentially explosive areas are covered in addition by the 2014/34/EU ATEX Product Directive.

Our electronic products satisfy EMC (Electromagnetic Compatibility) Directive 2014/30/EC.

Mechanical pressure switches do not fall under the EMC Directive.

The Machinery Directive 2006/42/EC is not applicable, because our products are classed as components.

Our product designs are based upon „good engineering practise“ in line with Article 4, Paragraph 3 of the Pressure Equipment Directive (2014/68/EU), meaning neither a declaration of conformity may be issued nor a CE mark affixed.

The current product-specific CE declaration is available in the download area of our homepage:

www.suco.de/en/downloads



Subject to technical changes